

< [Previous](#) [Next](#) >

2016 - CX-3 - Body and Accessories

FRONT FOG LIGHT AIMING

NOTE:

- If the following servicing is done, perform the front fog light aiming adjustment.
 - Front fog light replacement
 - Suspension replacement and removal/installation, servicing requiring vehicle height to be changed
1. Empty the vehicle except for the spare tire, jack and vehicle tools.
 2. Adjust the tire pressure to the specification. (See [WHEEL AND TIRE SPECIFICATION](#).)
 3. Move the vehicle to level ground.
 4. Sit on the driver-side seat alone.
 5. Make an adjustment-use screen as shown in the figure using double-weight, white paper. (Common to both left and right)

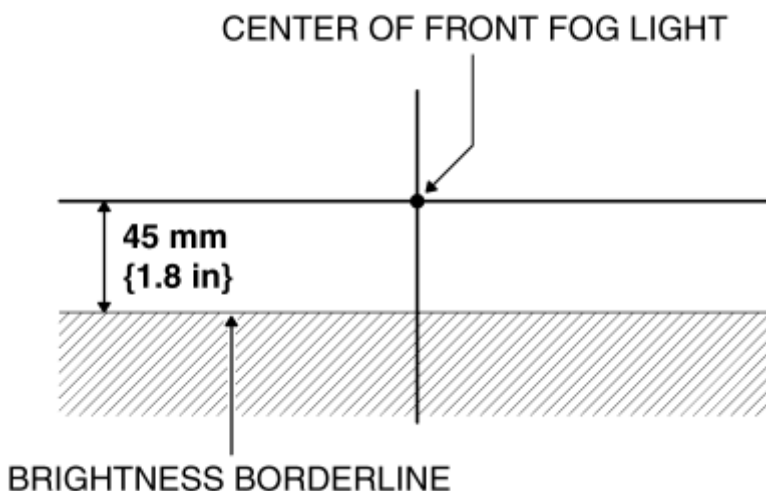

6. Line up the vehicle with the wall so that the distance to the front fog lights is 3 m {118 in} from the wall.

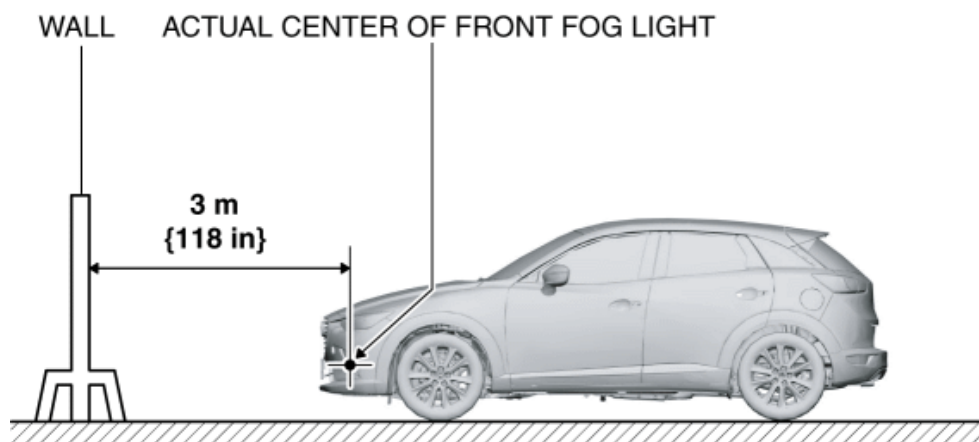

7. Measure the height at the center point of the front fog lights.

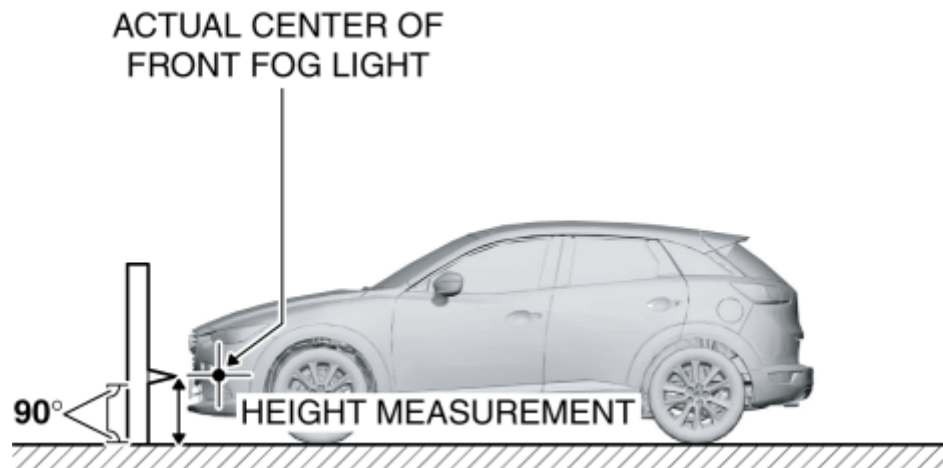
**NOTE:**

- Measure the height at the center point of the front fog light in which the aiming is being adjusted because the vehicle height differs depending on vehicle conditions.

8. Align the center of the front fog light to be adjusted with the center of the front fog light on the adjustment screen.

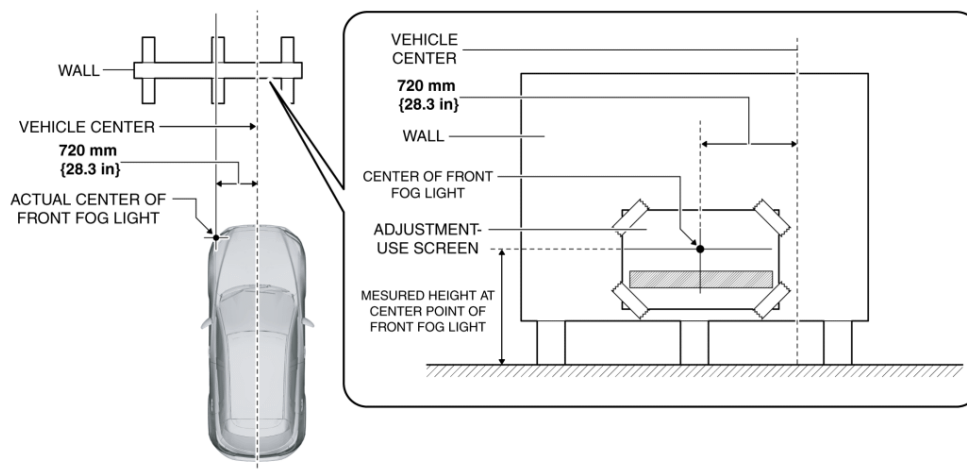

9. Set a partition in front of the front fog light which is not being adjusted to block the light.

10. Start the engine and charge the battery.

11. Turn on the front fog lights.

12. Verify that the actual brightness borderline of the fog light is at the brightness borderline position indicated by the adjustment-use screen.

- If the actual brightness borderline is not in the position indicated on the adjustment-use screen, perform the following adjustment:
 - a. Rotate the adjustment screw to adjust the front fog light.

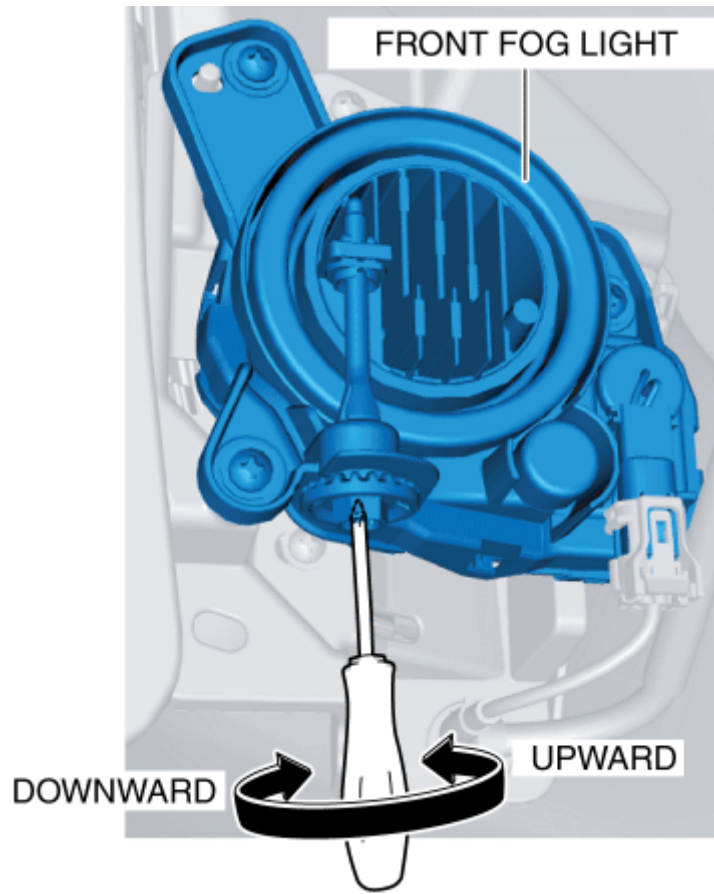

[< Previous](#) [Next >](#)

[Back to Top](#)

© 2014 Mazda North American Operations, U.S.A.

