

MAZDA

GB WELCOME ILLUMINATION Installation instruction	N INTERIØRLYS Monteringsvejledning
D INNENRAUMBELEUCHTUNG Einbauanleitung	S INNERBELYSNING Monteringsanvisning
E ILUMINACIÓN INTERIOR Instrucciones de montaje	SF SISÄVALO Asennusohje
F ÉCLAIRAGE INTÉRIEUR Notice de montage	CZ VNITŘNÍ OSVĚTLENÍ Návod k montáži
I ILLUMINAZIONE DELL'ABITACOLO Istruzioni di montaggio	H UTASTÉR-VILÁGÍTÁS Beszerelési utasítás
P LUZ INTERIOR Instruções de montagem	PL OŚWIETLENIE WNĘTRZA Instrukcja zabudowy
NL INTERIEURVERLICHTING Inbouw-instructie	GR ΦΩΤΙΣΜΟΣ ΕΣΩΤΕΡΙΚΟΥ ΧΩΡΟΥ Οδηγίες τοποθέτησης
DK KABINELYS Monteringsvejledning	RUS ВНУТРЕННЕЕ ОСВЕЩЕНИЕ инструкция по монтажу

CX-5 KE

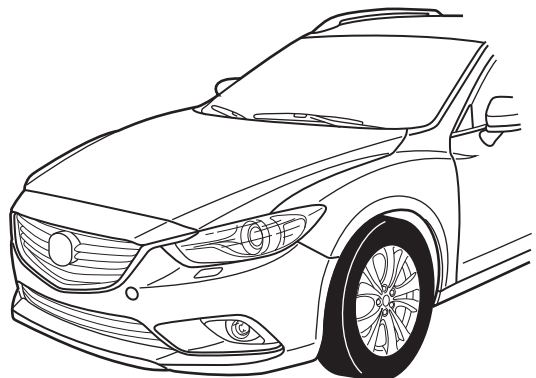
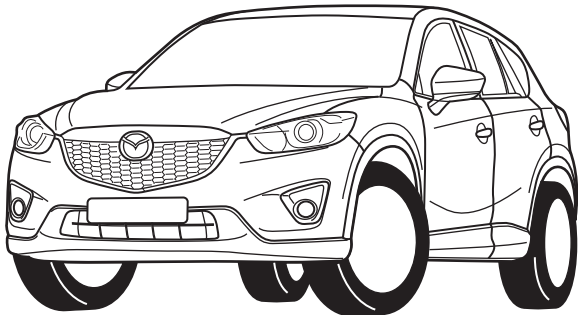

MAZDA 6 GJ

Part No: C832-V7-050B

Date: 03-12-'12

© Copyrights MAZDA

Sheet 1 of 24

Expert Fitment Required
Montage durch Fachwerkstatt erforderlich
Montaje sólo por el concesionario
Montage par spécialiste nécessaire
E' necessario in officina specializzata
Especialista em montagem requerido
Montage door vakman nodig
Montage ved professionelt værksted påkrævet
Nødvendig med montering fra fagvevkersted
Verkstadsmontage erfordras
Asennus tarpeen merkkikorjaamossa
Montáž ve specializované díně nutná
A szereléshez szakmühely kell
Konieczny montaż przez warsztat specjalistyczny
Na τοποθεί από συνεργείο
необходим монтаж специалиста

GB
INSTRUCTION SHEET

Area of application:

- Not for Do It Yourself fitment.
- Check Radio Code.
- Disconnect the battery earth cable.
- To avoid damage to the wiring harness, ensure contact with sharp edges is prevented.
- Install parts as shown on illustrations.
- Re-connect battery.
- Re-fit panels, ensure that the wiring harness and other components are neatly and securely located.

D
EINBAUANLEITUNG

Verwendungsbereich:

- Montage durch Fachwerkstatt erforderlich
- Notieren Sie den Radiocode
- Massekabel von Batterie abklemmen.
- Zur Vermeidung von Beschädigungen an der Kabelisolation ist Berührung mit scharfen Kanten zu vermeiden.
- Teile gemäß Abbildung montieren.
- Batterie wieder anschließen.
- Paneele wieder anbringen; achten Sie darauf, daß der Kabelbaum und andere Teile ordnungsgemäß und genau positioniert sind.

I
ISTRUZIONI DI MONTAGGIO

Ambito di utilizzazione:

- Non per "do-it-yourself"
- Annotare il codice di sicurezza della radio
- Staccare il cavo di massa dalla batteria
- Allo scopo di evitare danni all'isolazione dei cavi, evitare di metterli a contatto con spigoli acuti.
- Montare le parti secondo quanto rilevabile delle illustrazioni.
- Riconnettere la batteria.
- Rimettere in posizione i pannelli; far ben attenzione che il fascio di cavi e le altre parti siano state posizionate con esattezza e nella dovuta maniera.

E
INSTRUCCIONES DE MONTAJE

Campo de aplicación:

- "No para montarlo uno mismo"
- Anote el código de seguridad de la radio.
- Desconectar el cable de masa de la batería.
- A efectos de evitar desperfectos en el aislamiento del cable, hay que evitar el contacto con aristas cortantes.
- Montar las piezas tal como se indica en las figuras.
- Vuelva a conectar la batería.
- Volver a colocar los paneles; preste atención a que el mazo del cable y las demás piezas tengan la posición correcta y precisa.

F
NOTICE DE MONTAGE DU KIT

Utilisation:

- Le montage doit être effectué par un spécialiste.
- Notez le code de l'autoradio.
- Débranchez le câble de masse de la batterie.
- Eviter tout contact avec des arêtes vives afin de ne pas endommager l'isolation des câbles.
- Montez les pièces selon les figures.
- Reconnectez la batterie.
- Remettre le panneau; veillez à ce que le faisceau et les autres pièces soient positionnés correctement et avec la précision requise.

NL
MONTAGEAANWIJZING

Toepassingsgebied:

- Niet voor "doe-het-zelf"-montage.
- Radiocode noteren.
- Massakabel van accu losmaken.
- Ter vermindering van beschadigingen aan de isolatie van de elektrokit dient contact met scherpe kanten te worden vermeden.
- Delen overeenkomstig afbeelding monteren.
- Accu weer aansluiten.
- Panelen weer monteren; let erop, dat de kabelboom en andere delen correct en netjes gepositioneerd worden.



INSTRUÇÕES DE MONTAGEM

Campo de utilização:

- No é destinado à auto-montagem”
- Tome nota do número de código do rádio.
- Separe o cabo de terra do acumulador.
- Para não se danificar a isolamento dos cabos, é conveniente evitar-se contacto com arestas afiadas.
- Monte as partes conforme ilustrado.
- Recolocar a bateria
- Tornar a colocar os painéis; verificar se a árvore de cabos e outras peças estão na posição exacta e prescrita.



MONTERINGSVEILEDNING

Bruksområde:

- ”Ikke for selvmontering”
- Noter deg radiokoden
- Klem jordkabelen av batteriet.
- For å unngå skader på kabelisoleringen må berøring av skarpe kanter unngås.
- Monter alle deler i henhold til illustrasjonene.
- Tilkoppl batteriet igjen.
- Monter panelene igjen, og pass på at kabelbunten og andre deler er anbrakt ordentlig og på riktig sted.



MONTERINGSANVISNING

Användningsområde:

- ”Ej för självmontage”.
- Anteckna radiokoden.
- Lossa stomkabeln från batteriet.
- För att förhindra skador på ledningarnas isolation skall berøring med vassa kanter undvikas.
- Montera detaljerna enligt figurerna
- Anslut batteriet igen.
- Sätt tillbaka panelerna igen; kontrollera noga att ledningsmattan och andra detaljer ligger på rätt plats.



MONTAGEVEJLEDNING

Anvendelsesområde:

- ”Ikke til do-it-yourself montering”
- Noter radiokoden
- Stelkabel fjernes fra batteri.
- Berøring med skarpe kanter skal undgås for at undgå beskadigelse af kabelisoleringen.
- Dele skal monteres i henhold til illustrationer.
- Tilslut batteri igen.
- Paneler fastgøres igen; vær opmærksom på, at kabelsamlingen og andre dele placeres korrekt og præcist.



ASENNUSOHJE

Käyttöalue:

- ”Ei Tee-se-itse-asennukseen”.
- Merkitse radion koodi muistiin.
- Erotta maadoitusjohto akusta
- Pidä huoli myös siitä, että kaapelointi on korin kiinnityksen myötäinen ja kiinnitetty huolellisesti muihin liikkuviin osiin.
- Asenna osat kuvien mukaan.
- Kytke akku takaisin.
- Aseta paneelit paikalleen; tarkista, että kaapelointi ja muut osat ovat asianmukaisesti ja tarkalleen paikoillaan.



NÁVOD K MONTÁŽI

Oblast použití:

- Není určeno pro neodbornou montáž.
- Poznamenejte si kód rádia.
- Odpojte zemnicí kabel od baterie.
- Zabraňte tomu, aby se kabely poškodily tím, že jsou položeny na ostrých hranách.
- Montujte části podle vyobrazení
- Opět připojit baterii.
- Opět připevněte panely; dbejte na to, aby svazek kabelů a ostatní části byly uloženy na správném místě.



BESZERELÉSI UTASÍTÁSA

Melyik gépjárműhöz:

- A beszerelés csak szakműhelyben hajtható végre
- Jegyezze meg a rádió biztonsági kódszámát.
- Húzza le az akkumulátor testkábeljét.
- A kábelszigetelés megsérülésének elkerülésére ügyeljen arra, hogy a kábel ne juthasson érintkezésbe éles peremű alkatrészekkel.
- Az alkatrészeket az ábrák szerint szerelje be.
- Ismét csatlakoztassa az akkumulátort.
- Szerelje vissza a fedőlapokat, ügyeljen arra, hogy a kábelek és a többi alkatrészek pontosan a számukra kijelölt helyen maradjanak.



INSTRUKCJA MONTAŻU

Zakres stosowania:

- Zestaw nie jest przeznaczony do montażu we własnym zakresie.
- Zanotować kod radia.
- Odłączyć przewód masy od akumulatora.
- Dla zapobieżenia uszkodzeniu izolacji chronić przed zetknięciem z ostrymi krawędziami.
- Zamontować części zgodnie z rysunkiem.
- Ponownie podłączyć akumulator.
- Na powrót osadzić osłony; zadbać aby wiązka kablowa i inne części były właściwie i dokładnie ułożone.



ΟΔΗΓΙΕΣ ΤΟΠΟΘΕΤΗΣΗΣ

Τομέας εφαρμογής:

- Δεν επιτρέπεται να το τοποθετήσετε οι ίδιοι σας.
- Σημειώστε τον κωδικό του ραδιοφώνου.
- Αποσυνδέστε το καλώδιο γείωσης από τη μπαταρία.
- Για να αποφευχθούν ζημιές στη μόνωση καλωδίων, να αποφεύγεται η επαφή των με αιχμηρές ακμές.
- Τοποθέτηση των μερών σύμφωνα με τις Εικόνες.
- Συνδέστε πάλι τη μπαταρία.
- Τοποθετήστε πάλι το κάλυμμα· προσοχή, η πλεξούδα καλωδίων και άλλα μέρη να είναι τοποθετημένα ακριβώς και σύμφωνα με τους κανονισμούς.



ИНСТРУКЦИЯ МОНТАЖА

Область применения:

- не для самостоятельного монтажа
- запишите код безопасности радиоприемника
- отключите у аккумулятора заземление на массу
- для избежания повреждения изоляции кабеля избегайте острых поверхностей
- части монтировать согласно рисунку
- подключите аккумулятор
- понели собрать; обратите внимание чтобы кабель и другие части были правильно и точно расположены.

Mazda Color Table

	GB	D	E	F	I	P	NL	DK
L	Blue	Blau	Azul	Bleu	Blu	Azul	Blauw	Blå
B	Black	Schwarz	Negro	Noir	Nero	Preto	Zwart	Sort
BR	Brown	Braun	Marrón	Marron	Marrone	Castanho	Bruin	Brun
DL	Dark blue	Dunkelblau	Azul oscuro	Bleu foncé	Blu scuro	Azul-escuro	Donkerblauw	Mørkeblå
DG	Dark green	Dunkelgrün	Verde oscuro	Vert foncé	Verde scuro	Verde-escuro	Donkergroen	Mørkegrøn
G	Green	Grün	Verde	Vert	Verde	Verde	Groen	Grøn
GY	Grey	Grau	Gris	Gris	Grigio	Cinzeno	Grijs	Grå
LB	Light blue	Hellblau	Azul claro	Bleu clair	Blu chiaro	Azul-claro	Lichtblauw	Lyseblå
LG	Light green	Hellgrün	Verde claro	Vert clair	Verde chiaro	Verde-claro	Lichtgroen	Lysegrøn
N	Natural colour	Naturfarben	Color natural	Nature	Colori naturali	Cores naturels	Naturel	Naturfarvet
O	Orange	Orange	Naranja	Orange	Arancione	Laranja	Oranje	Orange
P	Pink	Rosa	Rosa	Rose	Rosa	Rosa	Rosé	Rosa
R	Red	Rot	Rojo	Rouge	Rosso	Vermelho	Rood	Rød
PU	Purple	Purpur	Púrpura	Pourpre	Rosso porpora	Púrpura	Paars	Purper
SB	Sky blue	Himmelblau	Azul cielo	Bleu ciel	Celeste	Azul-céu	Hemelsblauw	Himmelblå
T	Yellow brown	Gelbbraun	Amarillo-marrón	Marron-jaune	Giallomarrone	Castanho-amarelado	Geelbruin	Gulbrun
W	White	Wei	Blanco	Blanc	Bianco	Branco	Wit	Hvid
Y	Yellow	Gelb	Amarillo	Jaune	Giallo	Amarelo	Geel	Gul
V	Violet	Violett	Violeta	Violet	Viola	Violeta	Violet	Violet

	N	S	SF	CZ	H	PL	GR	RUS
L	Blå	Blå	Sininen	Modrá	Kék	Niebieska	Μπλε	Синий
B	Sort	Svart	Musta	erná	Fekete	Czarna	Μαύρο	Черный
BR	Brun	Brun	Ruskea	Hnědá	Barna	Brązowa	Καφέ	Коричневый
DL	Mørkeblå	Mørkblå	Tummansininen	Tmavomodrá	Sötétkék	Granatowa	Σκούρο μπλε	Темно Синий
DG	Mørkegrønn	Mørkgrøn	Tummanvihreä	Tmavozelená	Sötétzöld	Ciemnozielona	Σκούρο πράσινο	Темно Зеленый
G	Grønn	Grøn	Vihreä	Zelená	Zöld	Zielona	Πράσινο	Зеленый
GY	Grå	Grå	Harmaa	edá	Szürke	Szara	Γκρι	Серый
LB	Lyseblå	Ljusblå	Vaaleansininen	Bleděmodrá	Világoskék	Jasnoniebieska	Ανοιχτό μπλε	Светло Синий
LG	Lysegrønn	Ljusgrøn	Vaaleanvihreä	Světlezelená	Világoszöld	Jasnozielona	Ανοιχτό πράσινο	Светло Зеленый
N	Naturfarger	Naturlärger	Luonnonväri	Přirodní barva	Természetes színü	Barwy naturalne	Φυσικά χρώμαστ	природный
O	Orange	Orange	Oranssi	Oranžová	Narancs	Pomarańczowa	Πορτοκαλί	Оранжевый
P	Rosa	Rosa	Rosa	Růžová	Rózsaszín	Różowa	Ροζ	Розовый
R	Rød	Rød	Punainen	ervená	Piros	Czerwona	Κόκκινο	Красный
PU	Purpur	Purpur	Purppura	Purpurová	Bíborvörös	Purpurowa	Μοβ	Сиреневый
SB	Himmelblå	Himmelsblå	Taivaansininen	Blankytná	Égszínkék	Bękitna	Γαλάζιο	лазурный
T	Gulbrun	Gulbrun	Keltaisenruskea	lutohnědá	Sárgásbarna	ółtobrązowa	Κίτρινοκαφέ	Желто-коричневый
W	Hvit	Vit	Valkoinen	Bílá	Fehér	Biała	Λευκό	Белый
Y	Gul	Gul	Keltainen	lutá	Sárga	ółta	Κίτρινο	Желтый
V	Fiolett	Violett	Violett	Fialová	Ibolyakék	Fioletowa	Μοβν	фиолетовый



- (GB) Location
- (D) Positionspfeil
- (E) Flecha de posición
- (F) Flèche de Position
- (I) Freccia di posizione
- (P) Flexa de posição
- (NL) Lokatie /Positie pijl
- (DK) Lokaliseringspil
- (N) Posisjonspil
- (S) Positionspil
- (SF) Paikannusnuoli
- (CZ) Šlipka na pozici
- (H) Helyzetjelzőnyíl
- (PL) Strzałka położenia
- (GR) Βέλος θέσης
- (RUS) Стрелка, указывающая на позицию



- (GB) Movement Arrow
- (D) Bewegungspfeil
- (E) Flecha de movimiento
- (F) Flèche de mouvement
- (I) Freccia di movimento
- (P) Flexa de movimento
- (NL) Richtingspijl
- (DK) Bevægelsespil
- (N) Bevegelsespil
- (S) Rörelsepil
- (SF) Liikesuuntanuoli
- (CZ) Šlipka pohybu
- (H) Mozgásirányjelző
- (PL) Strzałka kierunku ruchu
- (GR) Βέλος κίνησης
- (RUS) Стрелка, указывающая на перемещение



- (GB) Look/See
- (D) Siehe
- (E) Ver
- (F) Voir
- (I) Vedere
- (P) Cf.
- (NL) Kijken naar
- (DK) Se
- (N) Se
- (S) Se
- (SF) Katso
- (CZ) Viz
- (H) Lásd
- (PL) Patrz
- (GR) Βλέπε
- (RUS) Смотри



- (GB) Mirror image
- (D) Spiegelbild
- (E) Imagen simétrica
- (F) Image de miroir
- (I) Immagine dello specchio
- (P) Imagem do espelho
- (NL) Mirror beeld
- (DK) Spejlbillede
- (N) Speilbilde
- (S) Spiegelbild
- (SF) Peilikuva
- (CZ) Věrný obraz
- (H) Tükürcép
- (PL) Odbicie lustrzane
- (GR) εικόνακαθρεφτών
- (RUS) Зеркальное отражение



- (GB) Connect
- (D) Verbinden
- (E) Conectar
- (F) Raccorder
- (I) Collegare
- (P) Ligar
- (NL) In elkaar
- (DK) Kobles
- (N) Tilkopling
- (S) Anslut
- (SF) Yhdistä
- (CZ) Spojit
- (H) Kapcsolja össze
- (PL) Połączyć
- (GR) Σύνδεση
- (RUS) Соедините



- (GB) Disconnect
- (D) Abklemmen
- (E) Desconectar
- (F) Déconnecter
- (I) Staccare
- (P) Desligar
- (NL) Demonteren
- (DK) Frakobles
- (N) Klem av
- (S) Koppla los
- (SF) Irrota
- (CZ) Odpojit
- (H) Szakítsa meg, kapcsolja szét
- (PL) Rozłączyć
- (GR) Αποσύνδεση
- (RUS) Разъедините



- (GB) See Workshop Manual
- (D) Siehe Werkstatthandbuch
- (E) Ver manual de taller
- (F) Voir Manual d'atelier
- (I) Vedere manuale officina
- (P) Cf. o manual da oficina
- (NL) Zie werkplaatshandboek
- (DK) Se værkstedshåndbog
- (N) Se verkstedshåndboka
- (S) Se verkstedshanboken
- (SF) Katso korjaamon käsikirjasta
- (CZ) Viz dílenskou příručku
- (H) Lásd a Műhely-kézikönyvben
- (PL) Patrz podręcznik warsztatowy
- (GR) βλέπε ΕΥΧειρίδιο Σύνεργείου
- (RUS) Смотри текст

C832-V7-050

A

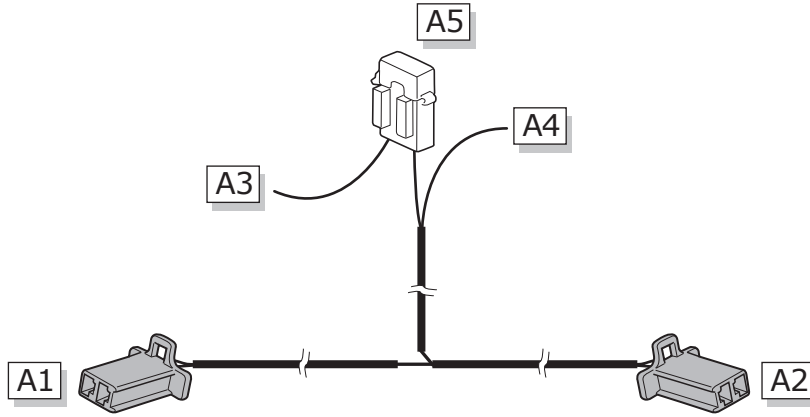

1x

B

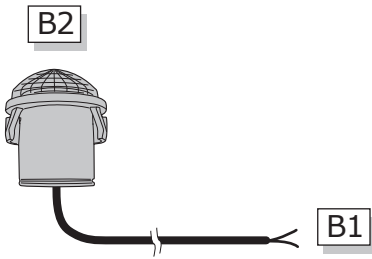

2x

C

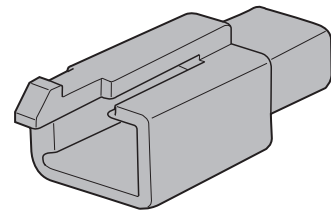

2x

D

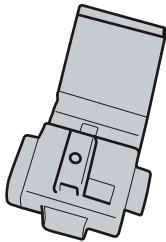

2x

E



1x

F

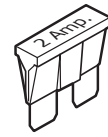

1x

C830-V7-700

G

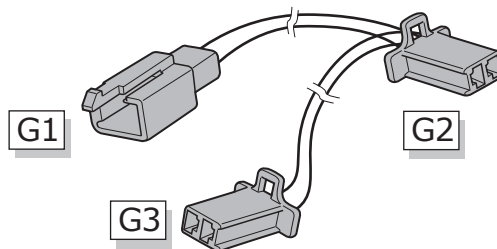

2x

MAZDA CX-5  1-16

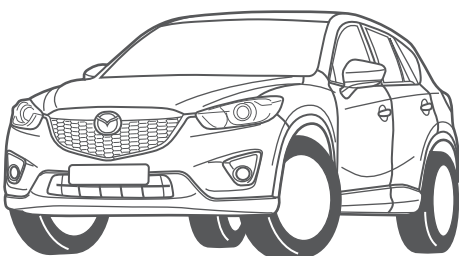

MAZDA 6 GJ  17-38

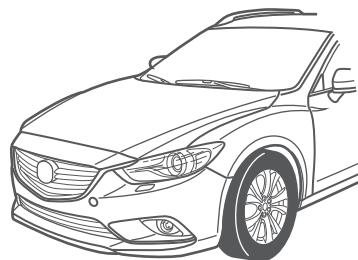

MAZDA CX-5

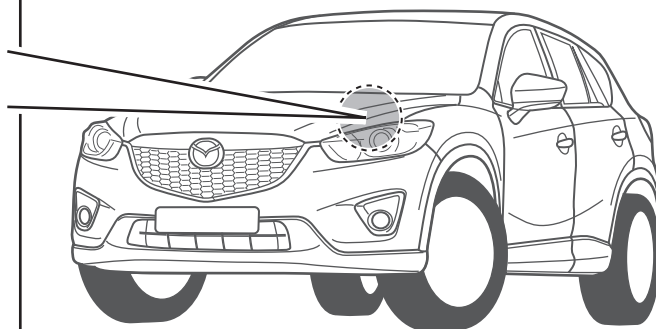
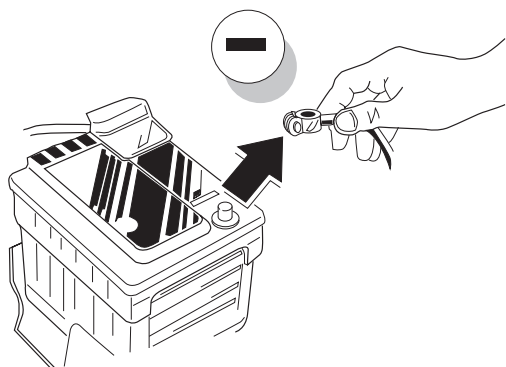

1

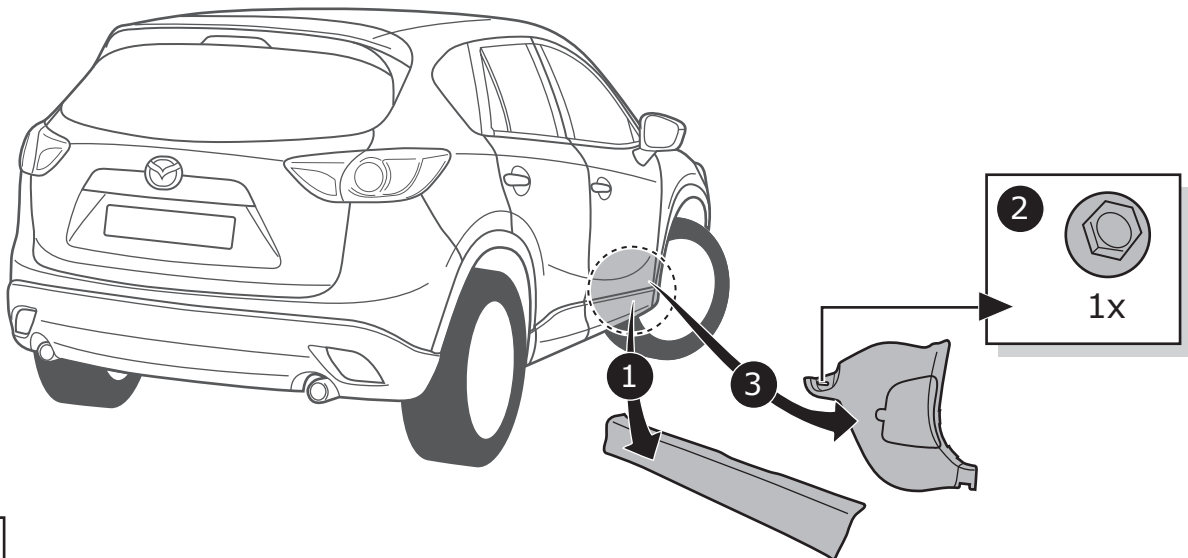
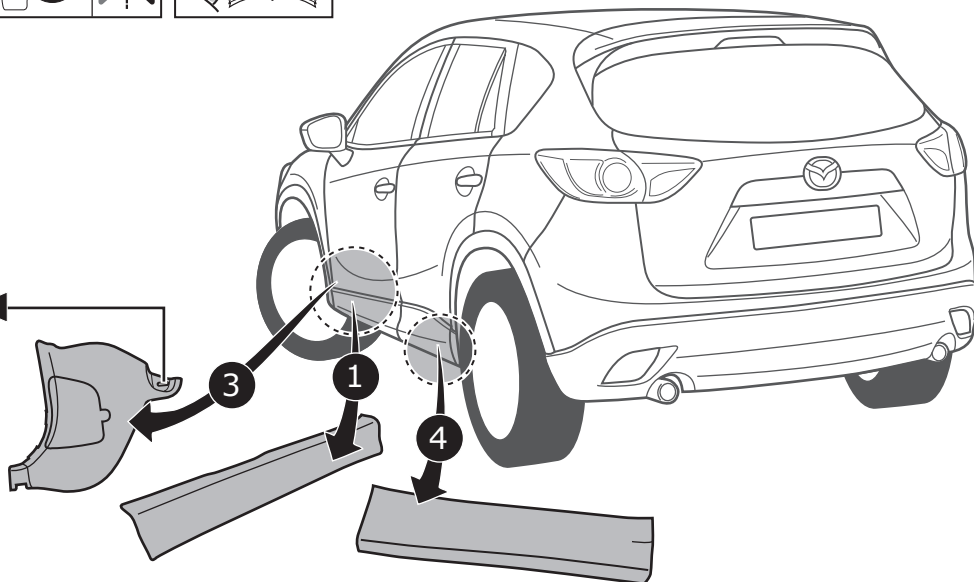
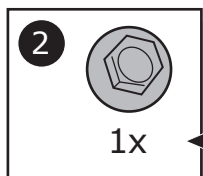
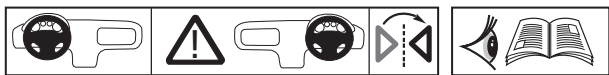

2

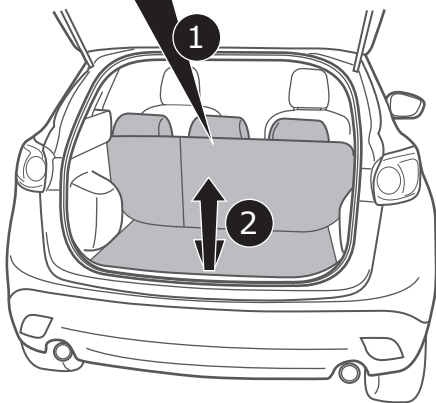
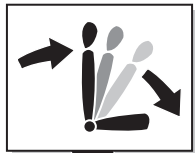

3

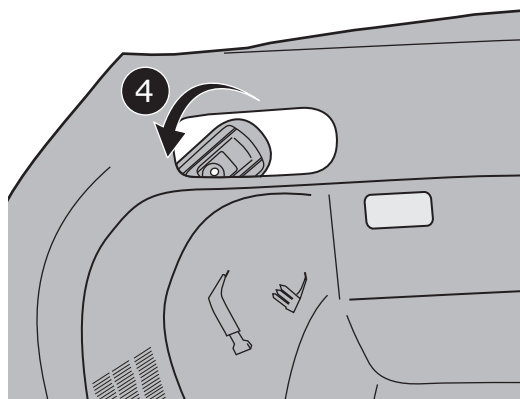
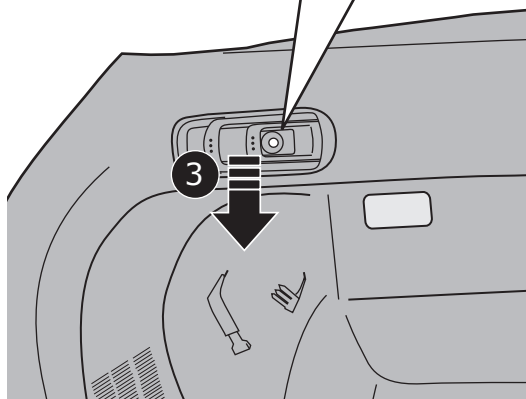
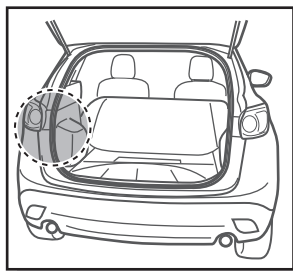
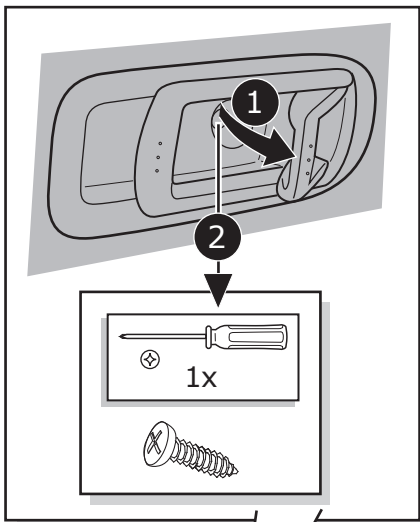
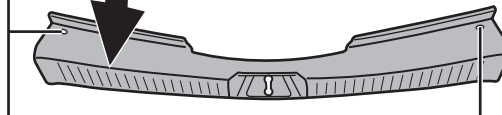
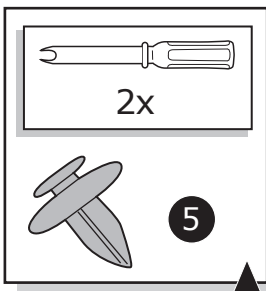
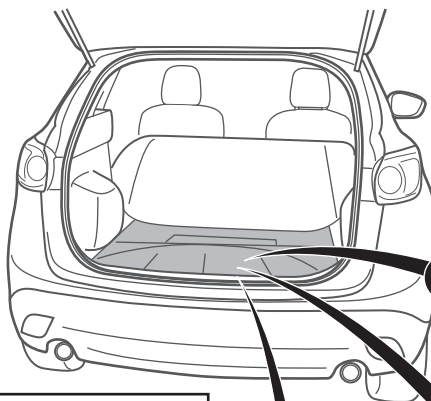

4

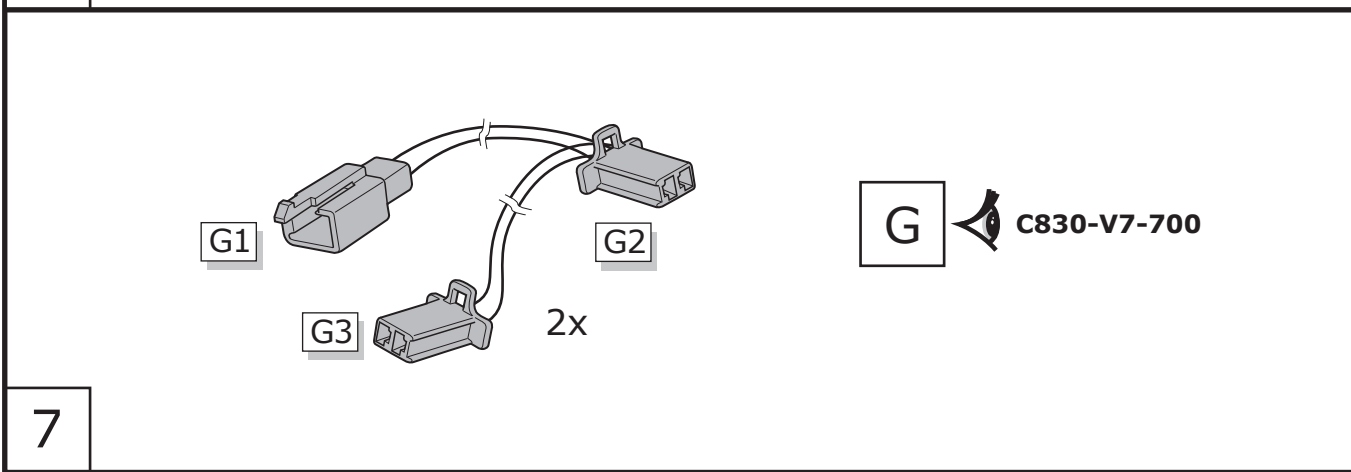
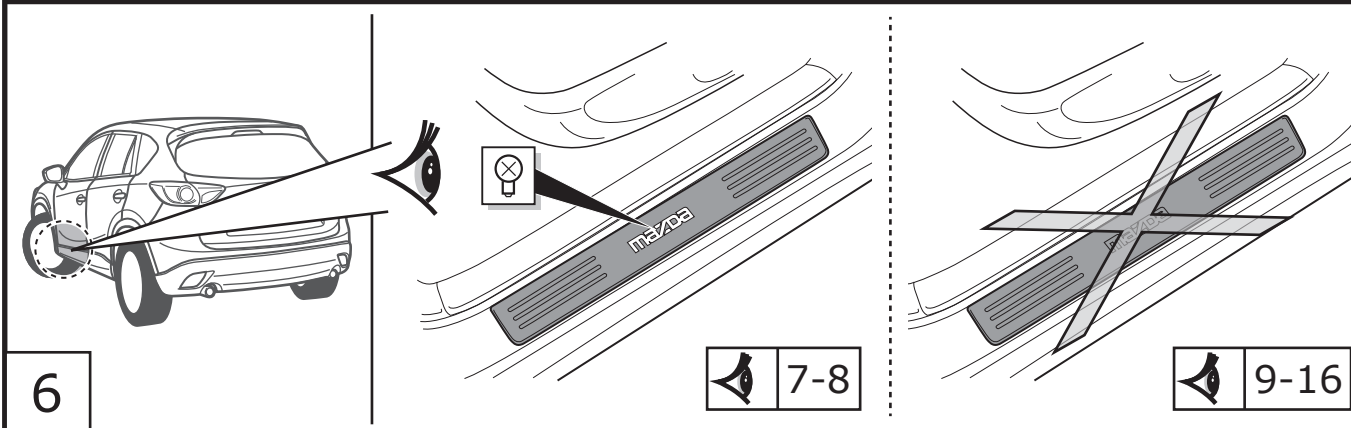
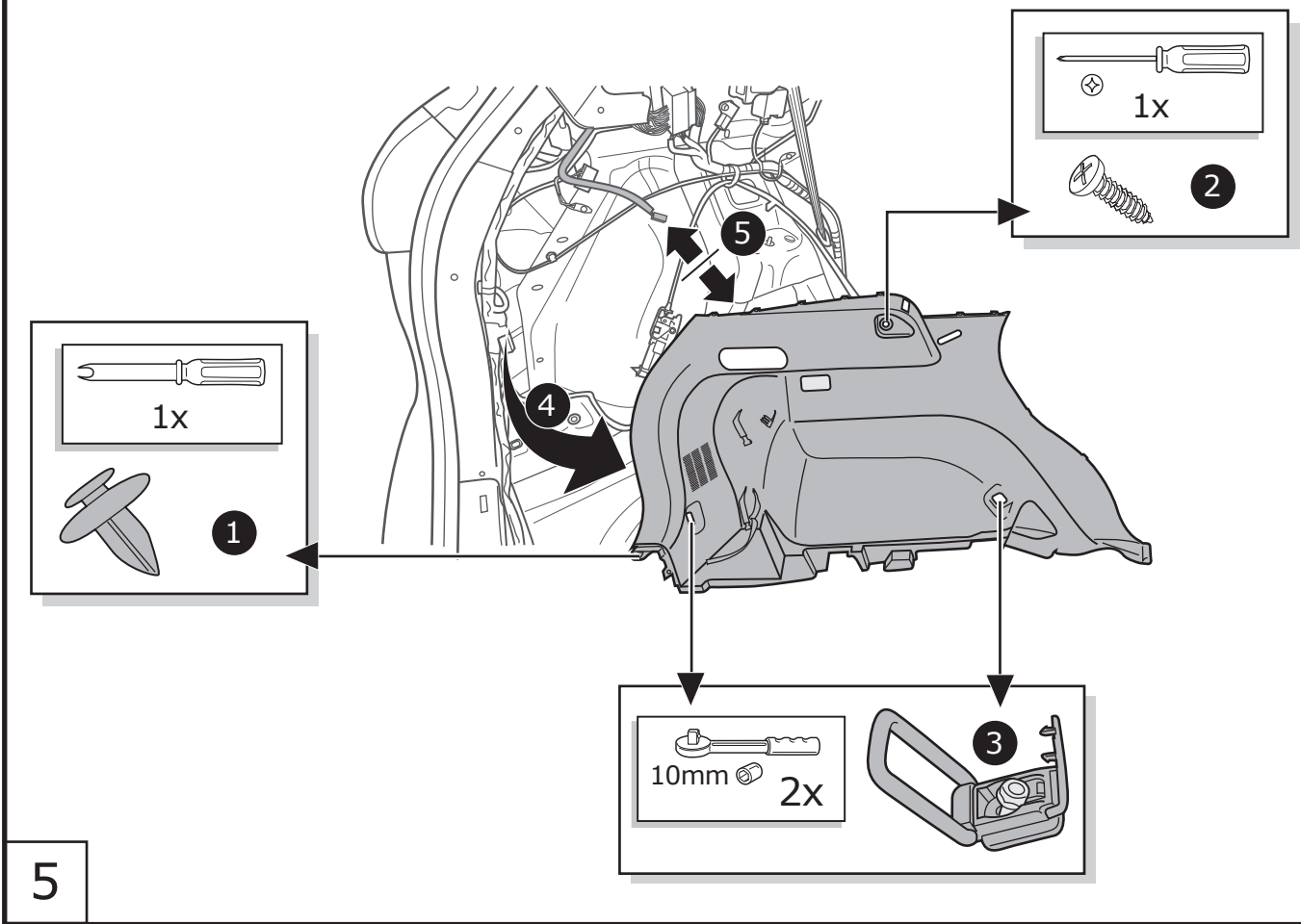

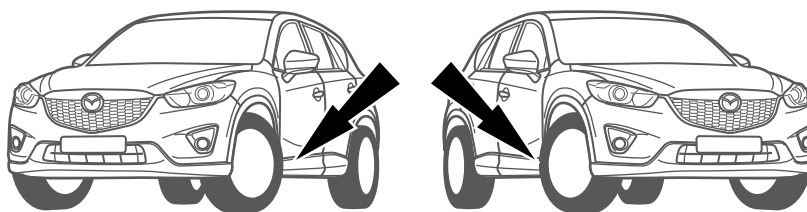

1

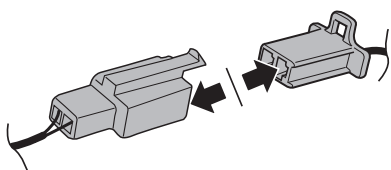

2

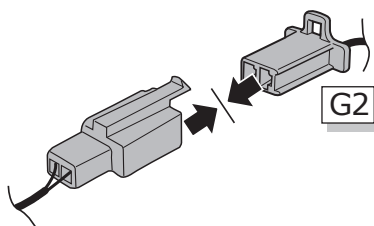

3

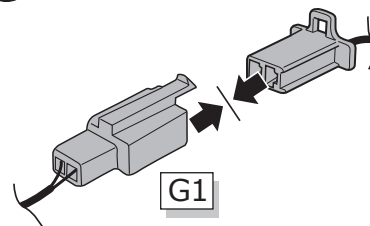

4

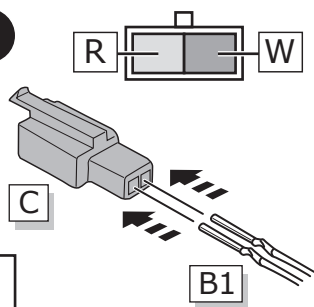

5

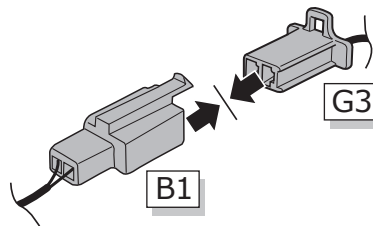

8

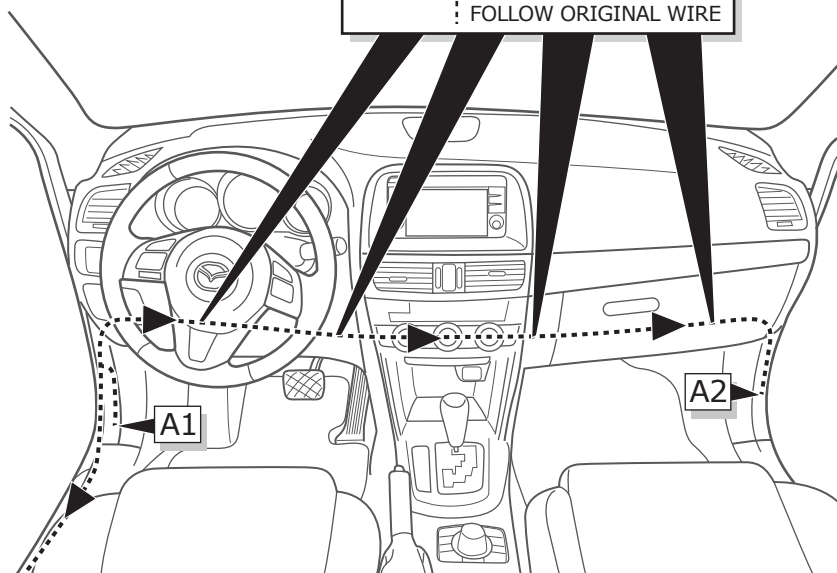
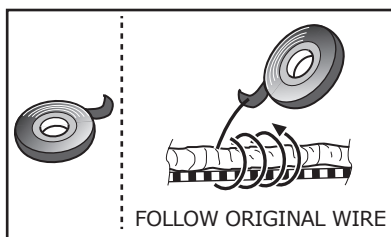

9

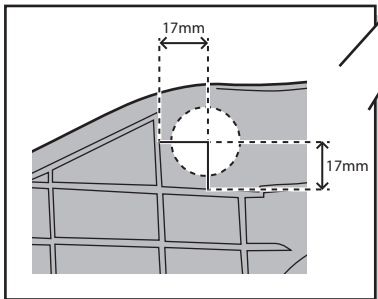
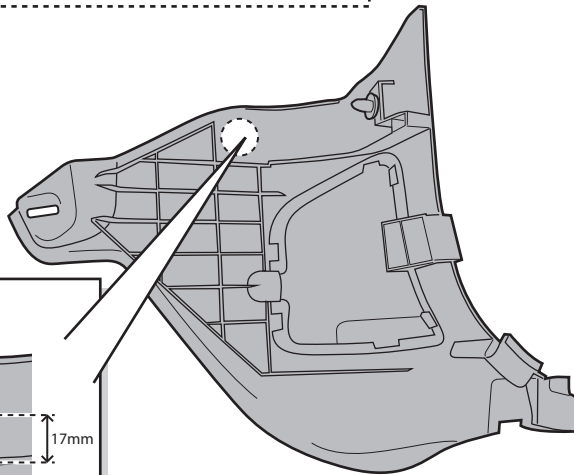
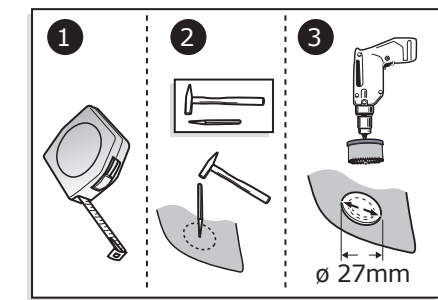

10

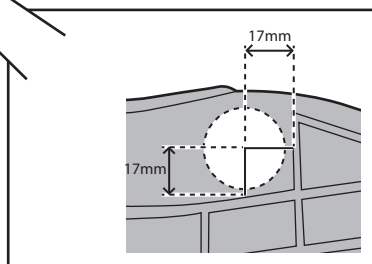
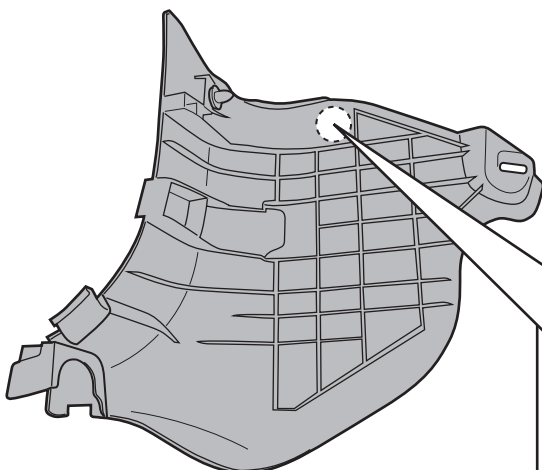
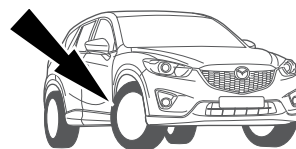
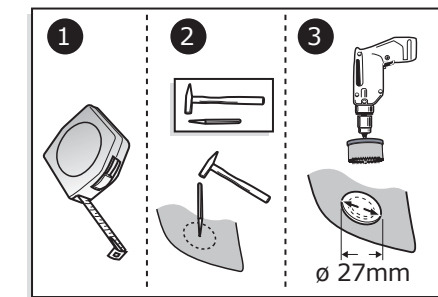
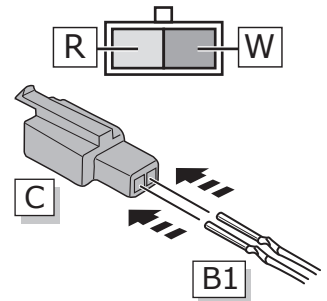
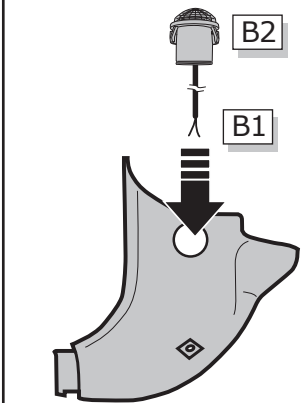

11

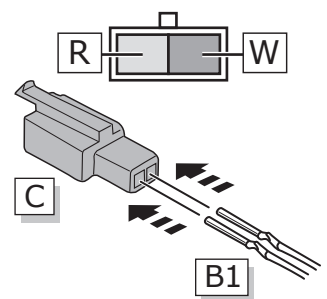
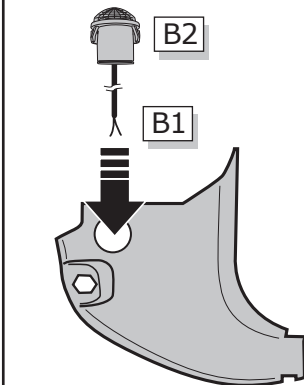

12

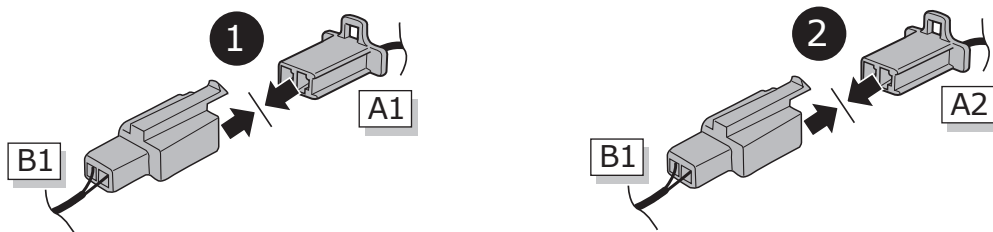

13

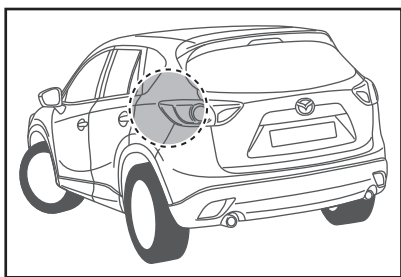
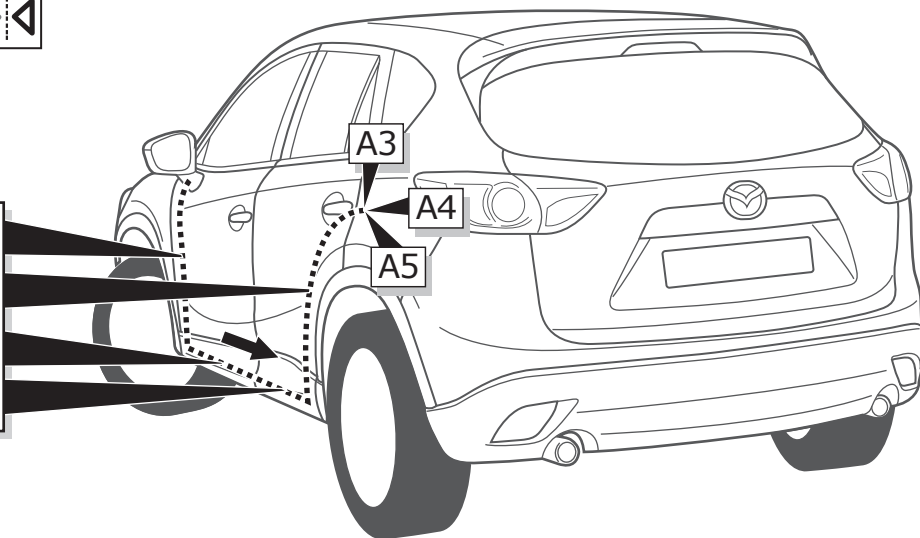
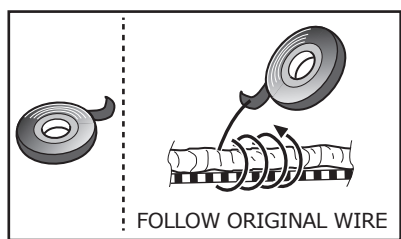

14

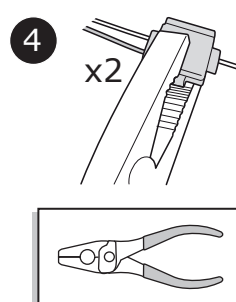
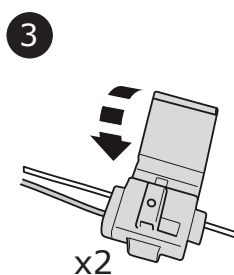
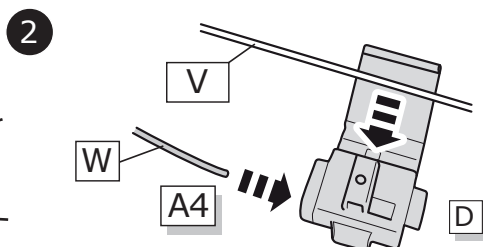
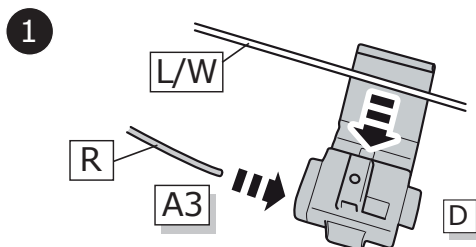
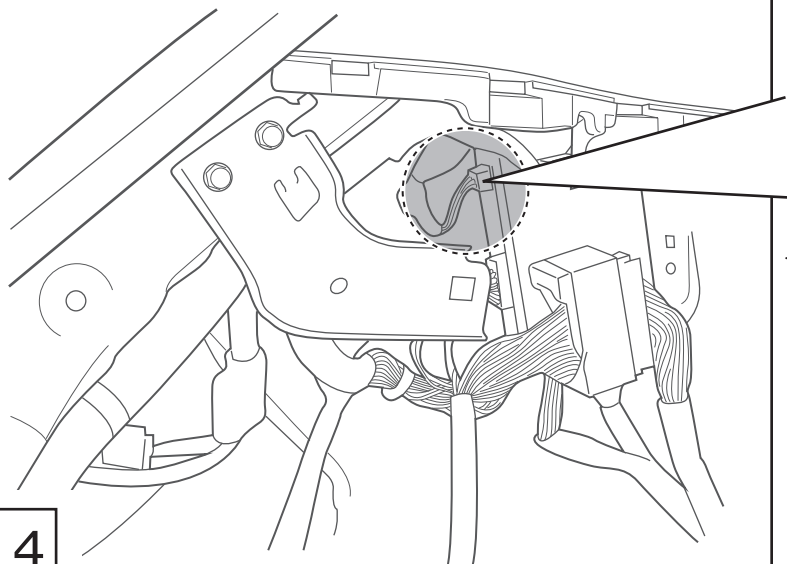

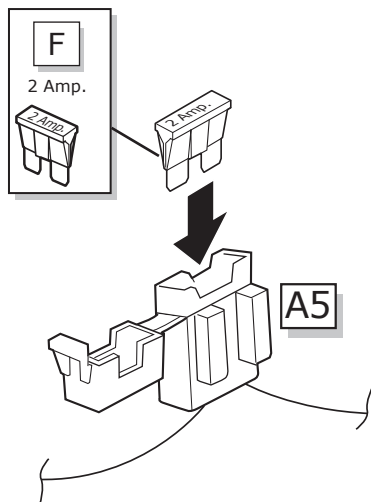

15

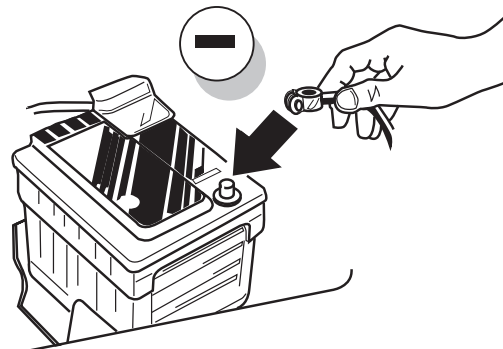

16

Subject to alteration without notice
 Technische Änderungen vorbehalten
 Reservadas modificaciones técnicas
 Sous réserve de modifications techniques
 Con riserva di apportare modifiche tecniche
 Reservamo-nos o direito a alterações técnicas
 Technische wijzigingen voorbehouden
 Med forbehold for tekniske forandringer
 Tekniske forendringer forbeholdes
 Med reservation för tekniska ändringar
 Tekniset muutokset pidätetään
 Technické zmeny vyhrazeny
 A változtatások technika jogát fenntartjuk
 Zmiany techniczne zastrzeżone
 Επιφυλασσόμεθα για αλλαγές

MAZDA 6 GJ



17

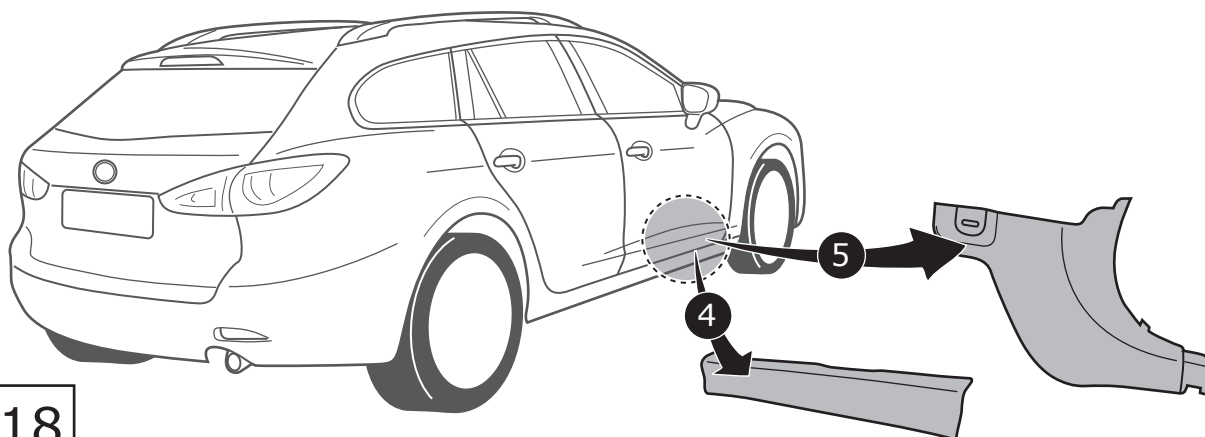
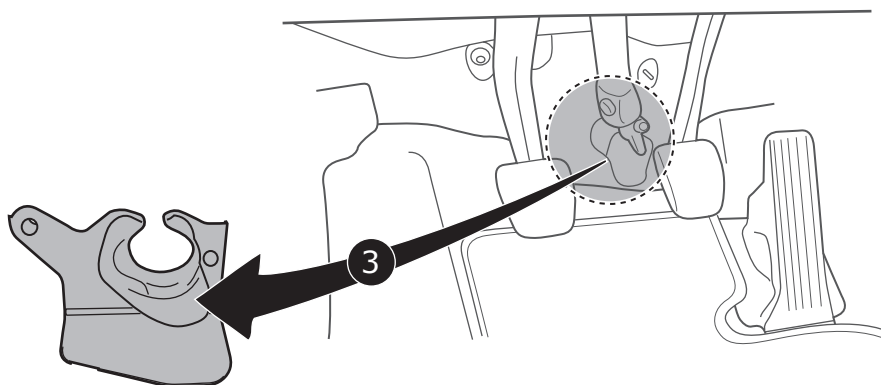
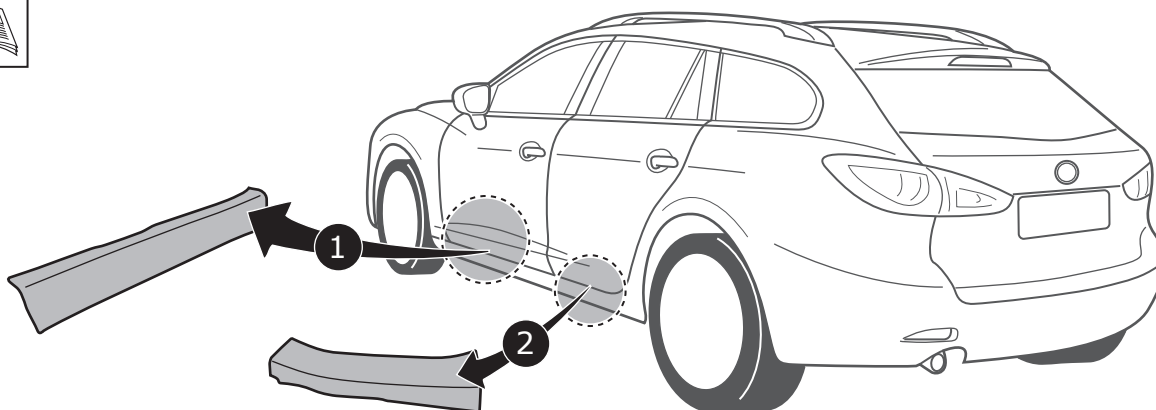
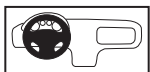
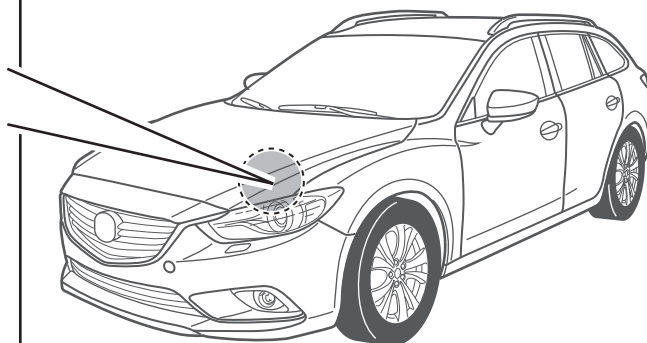
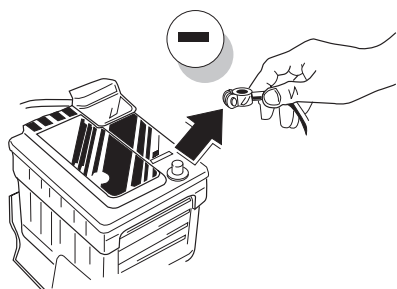

18

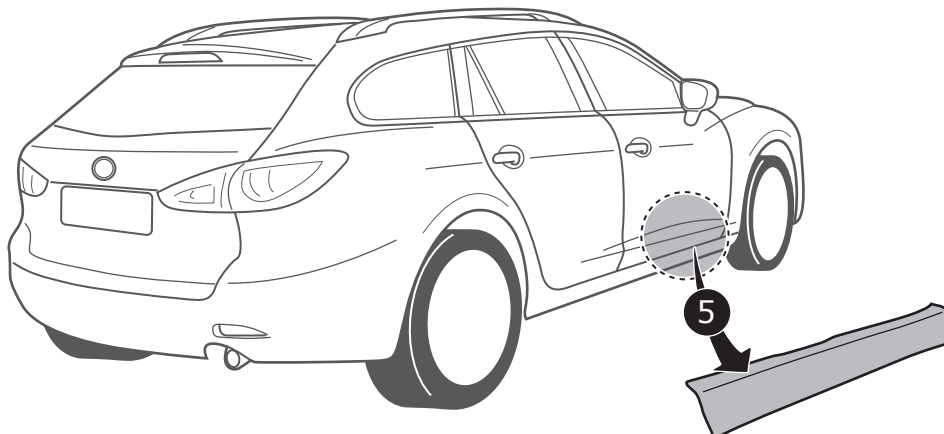
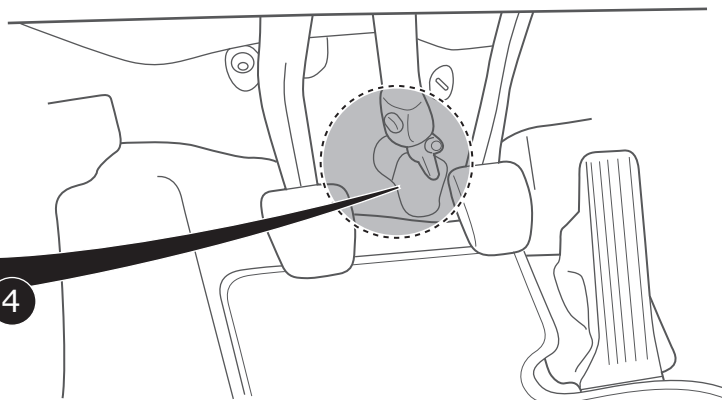
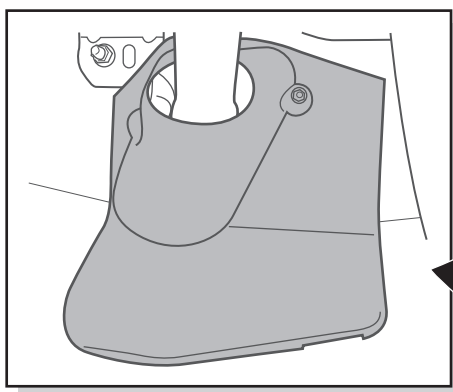
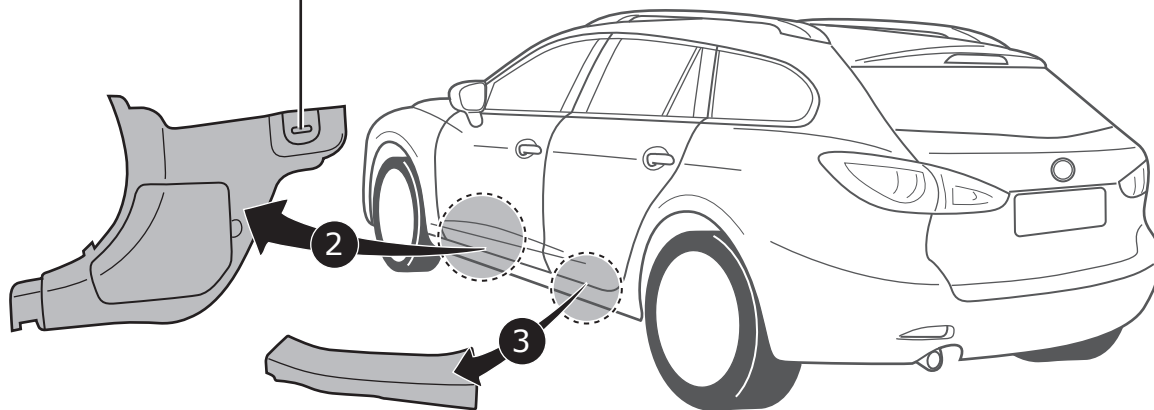
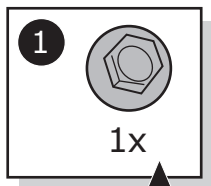
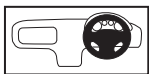



Wagon

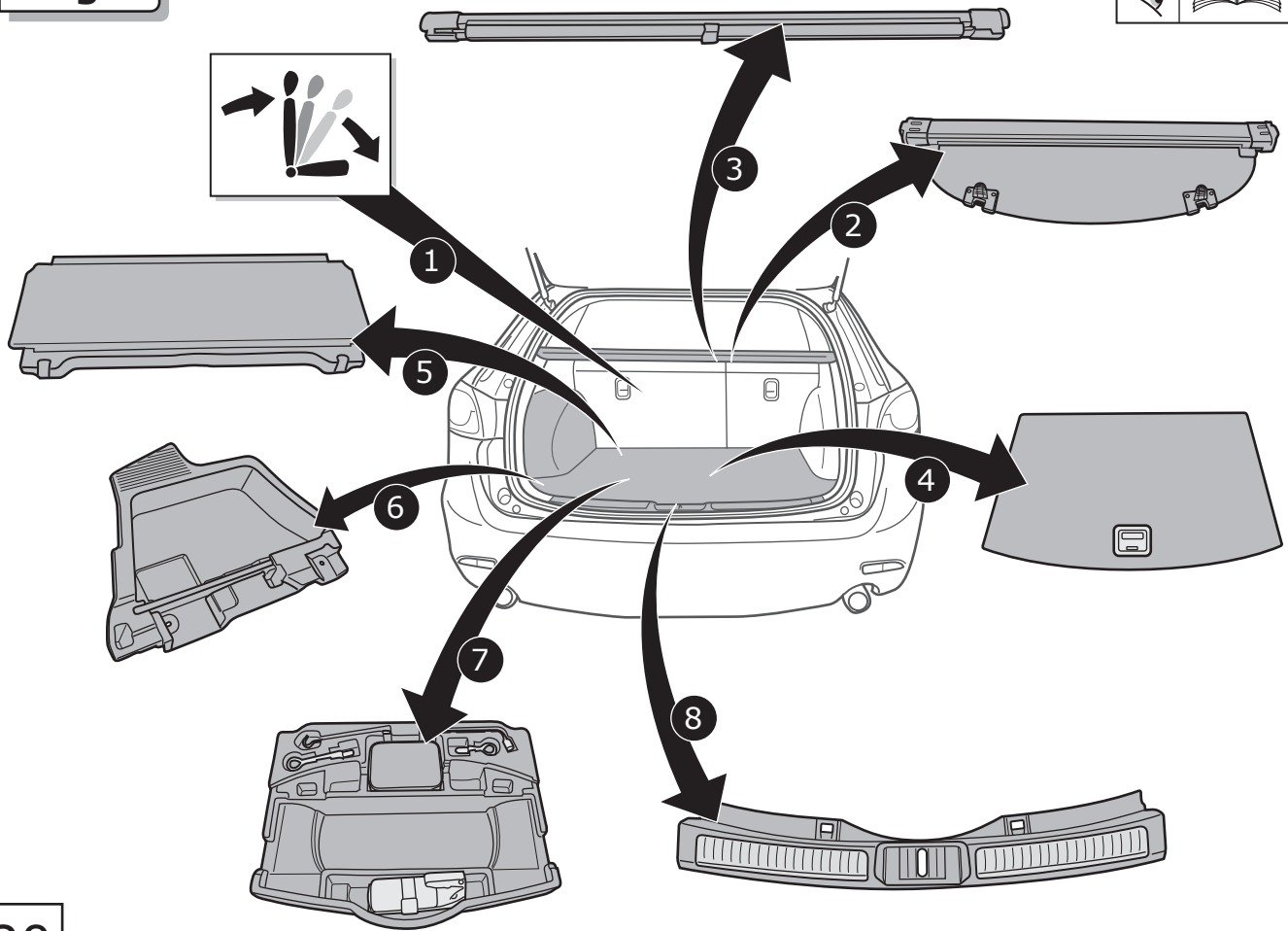

20

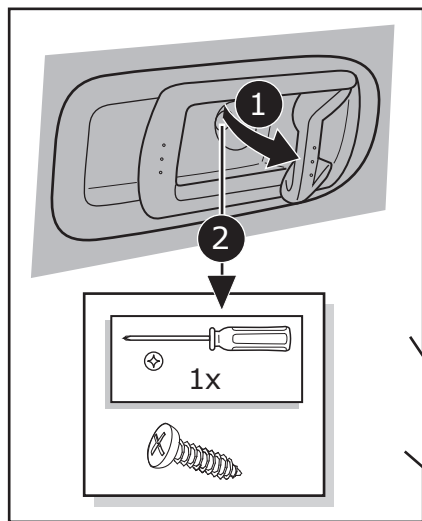

Wagon

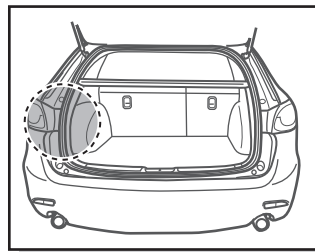

Wagon

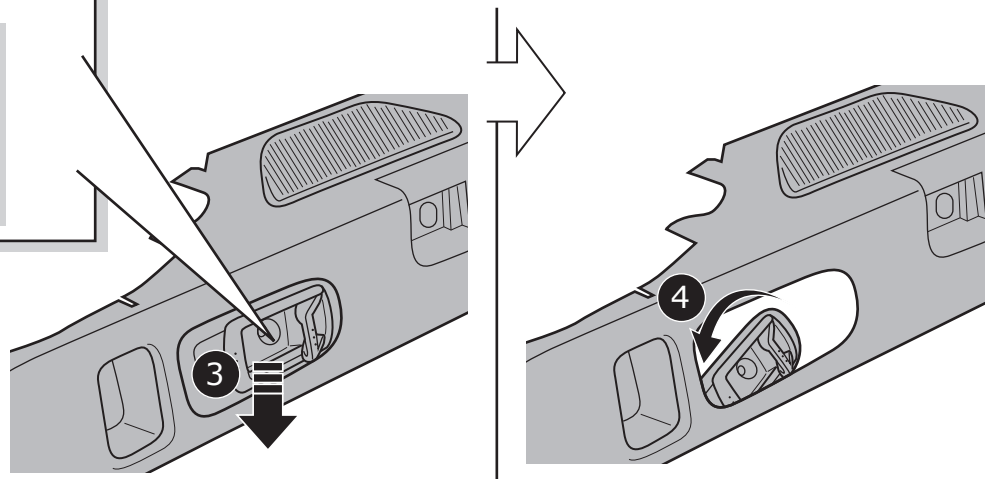

21

Wagon

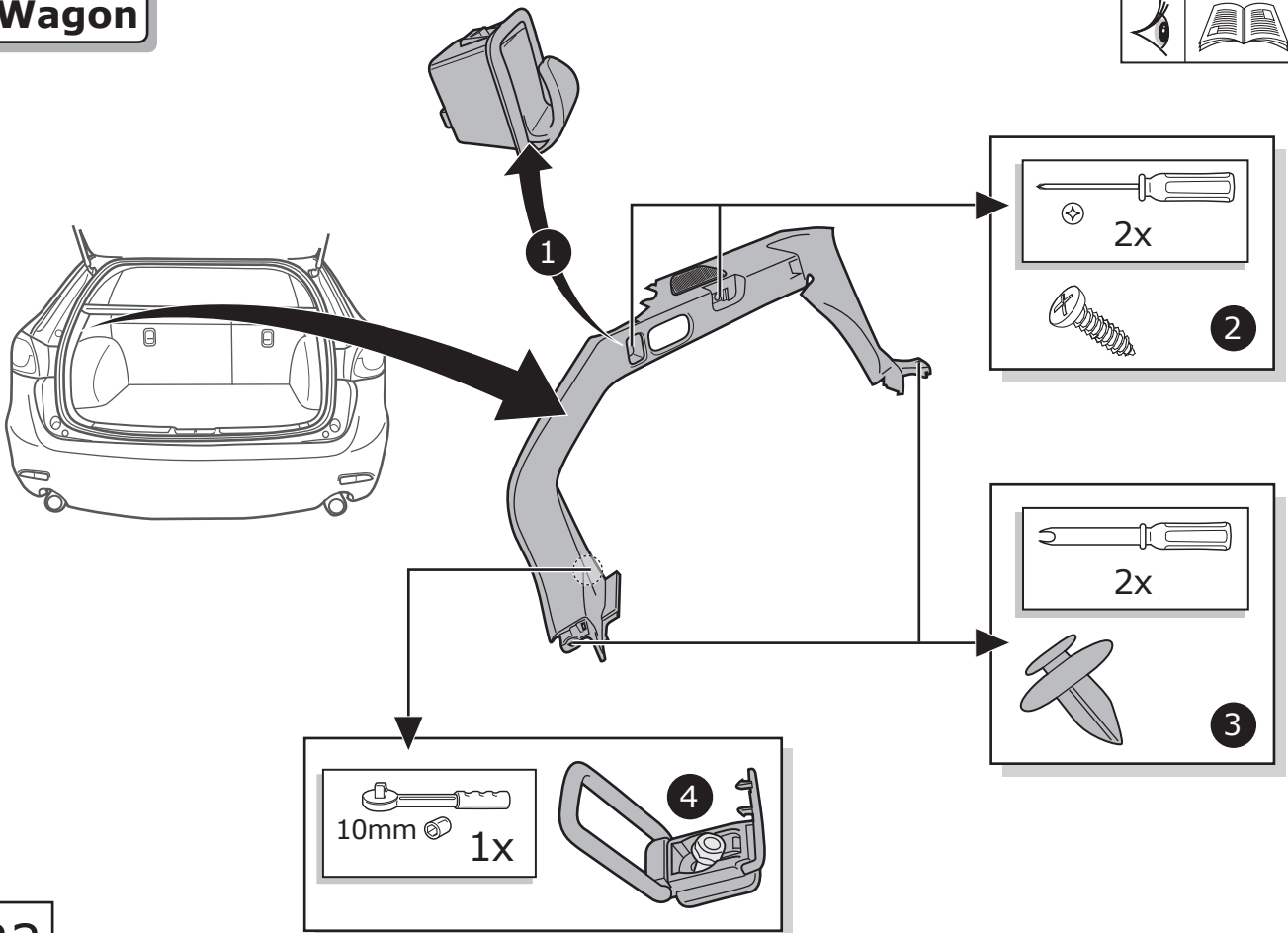

22



Sedan

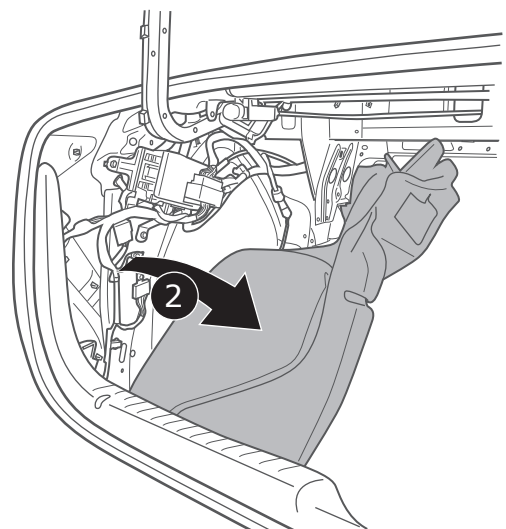
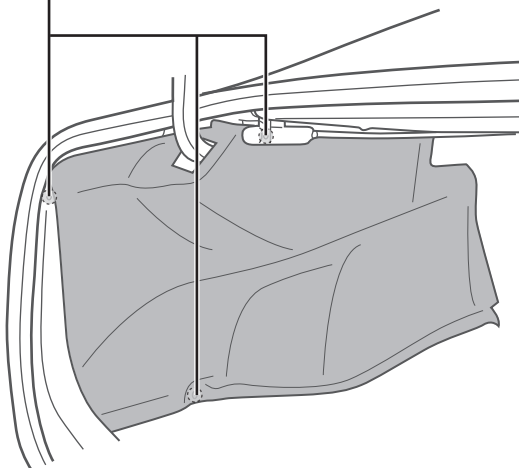
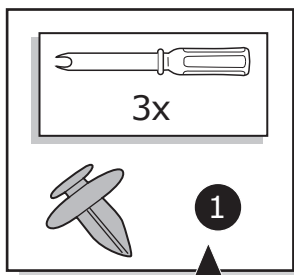

23

Wagon

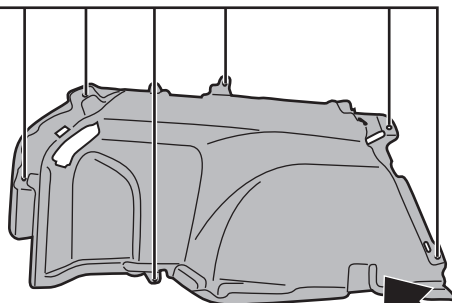
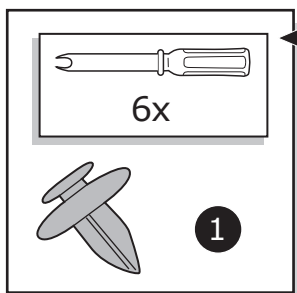

2

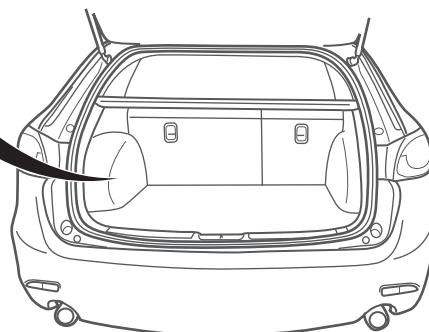

24

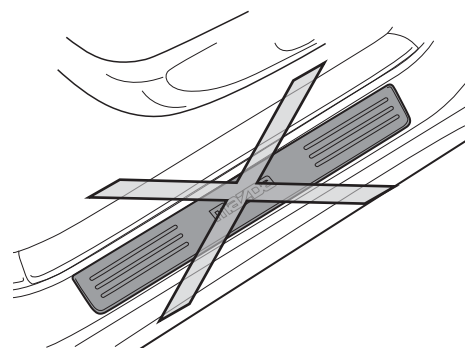
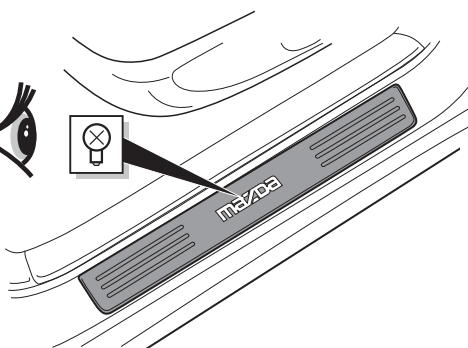
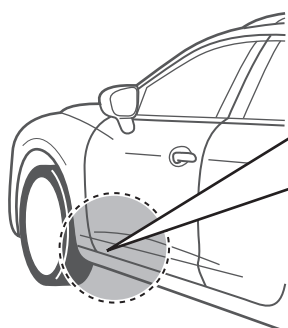

25

26-27

28-38

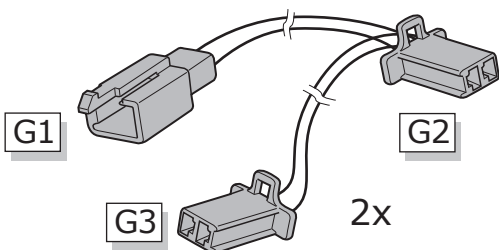

G C830-V7-700

26

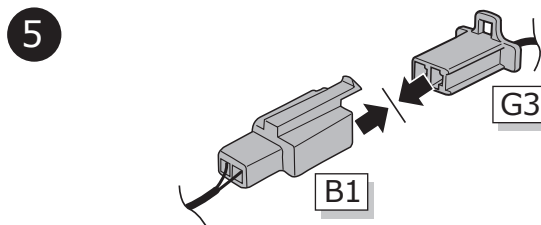
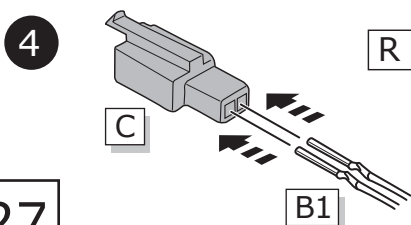
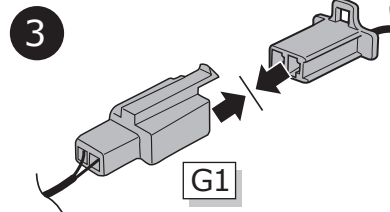
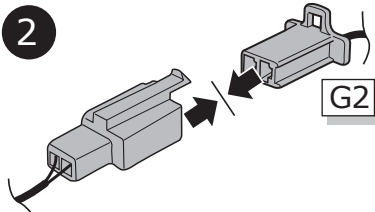
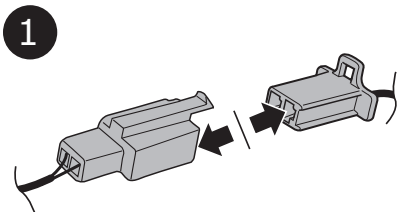
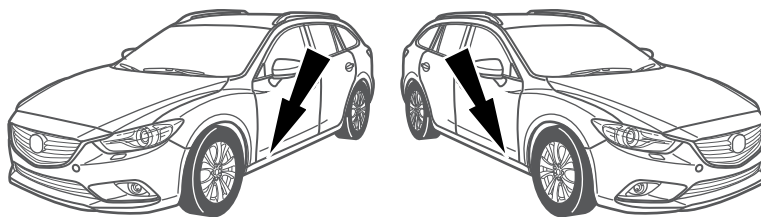

27

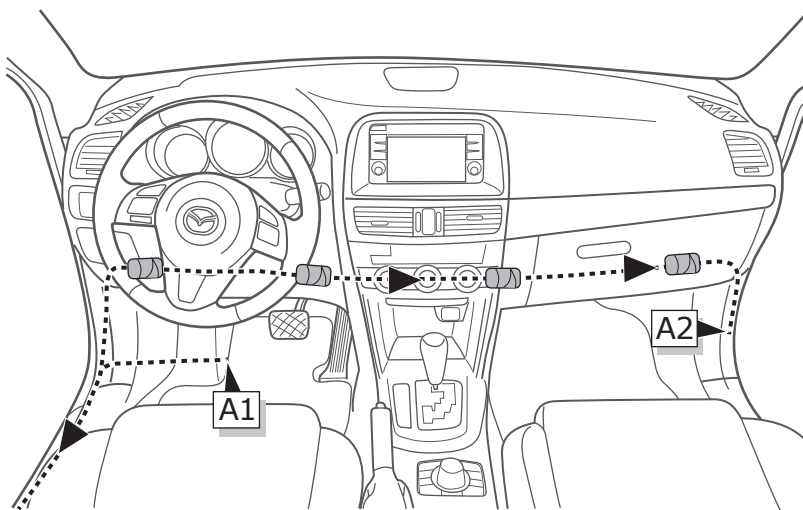
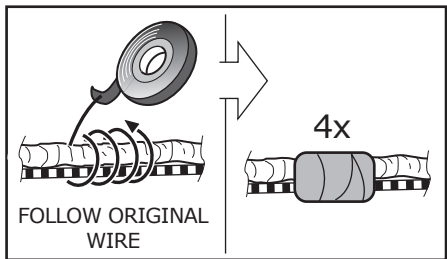

28

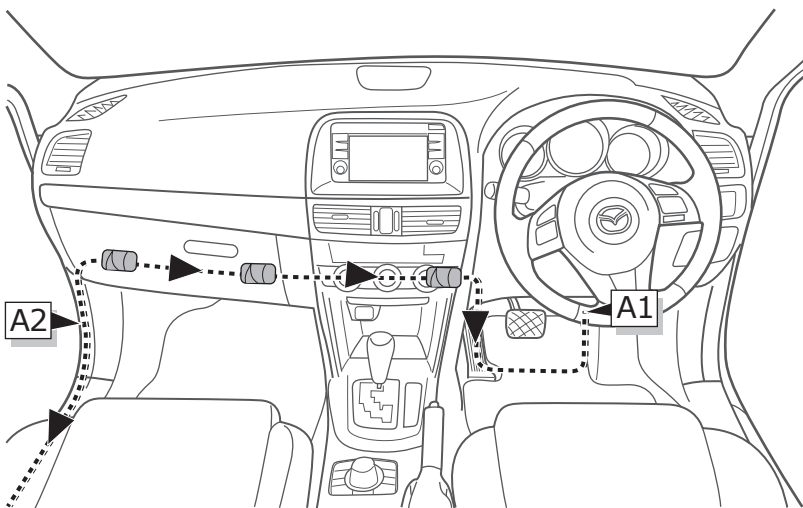
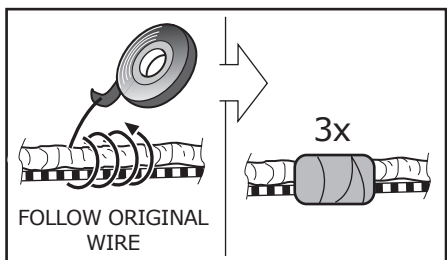

29

30

1 2 3

ø 27mm

50mm

18mm

B2

B1

R W

C

B1

31

1 2 3

ø 27mm

25mm

25mm

B2

B1

R W

C

B1

32

1 2 3

ø 27mm

50mm

50mm

20mm

B2

B1

R W

C

B1

33

1 2 3

ø 27mm

13mm

13mm

B2

B1

R W

C

B1

34

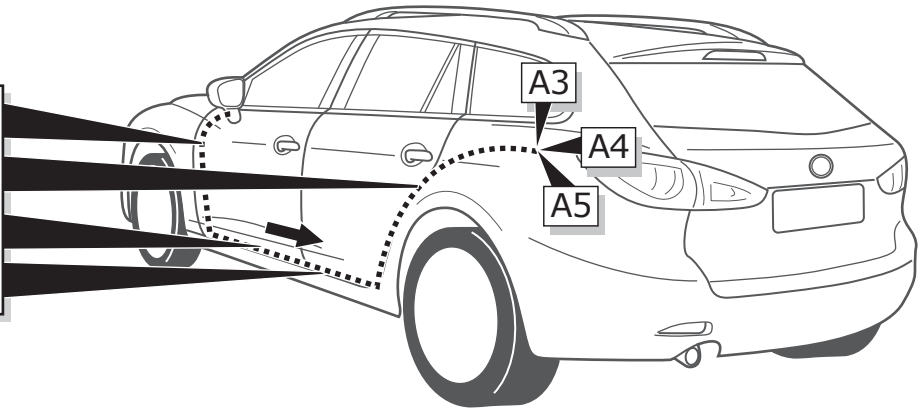
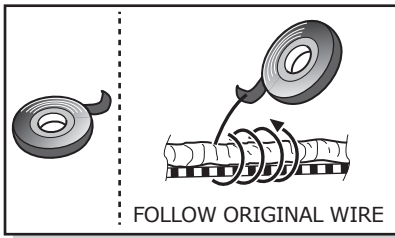
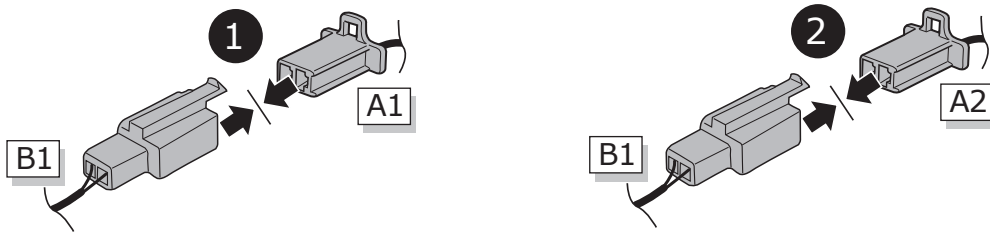

35

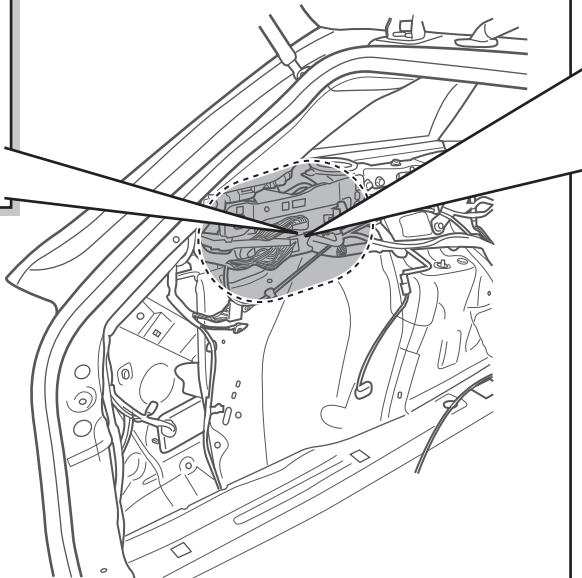
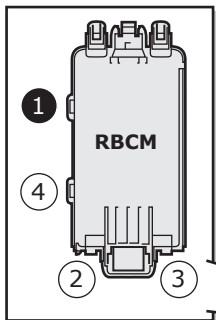
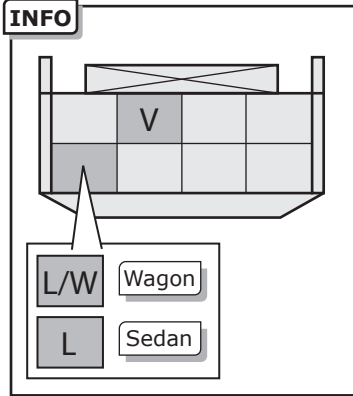
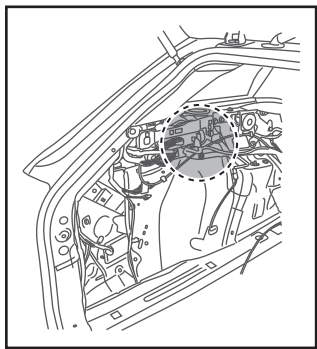

36

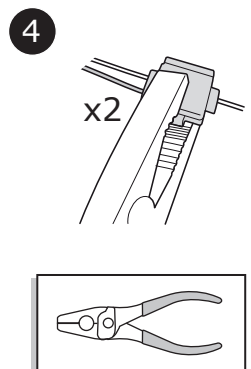
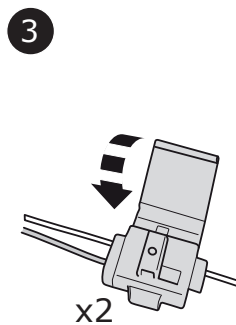
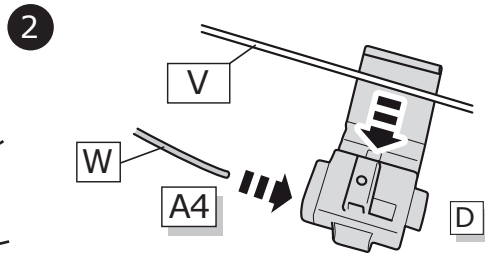
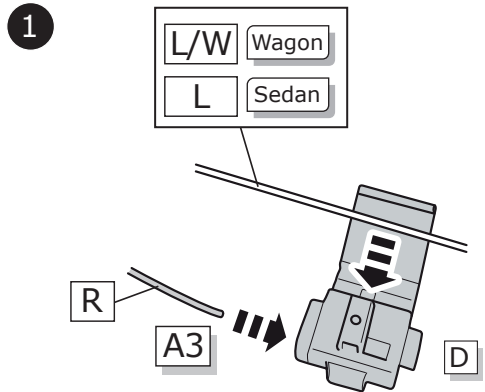

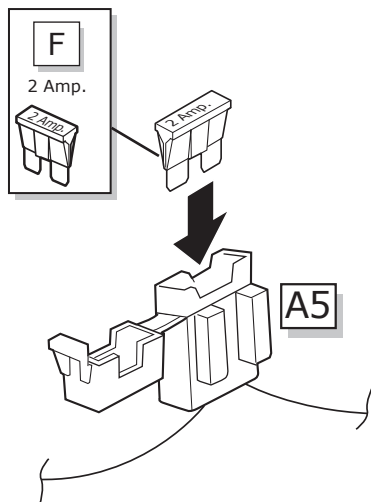

37

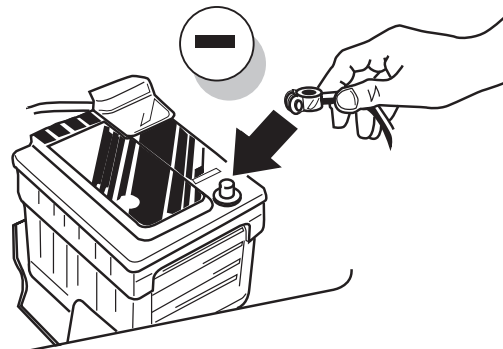

38

Subject to alteration without notice
 Technische Änderungen vorbehalten
 Reservadas modificaciones técnicas
 Sous réserve de modifications techniques
 Con riserva di apportare modifiche tecniche
 Reservamo-nos o direito a alterações técnicas
 Technische wijzigingen voorbehouden
 Med forbehold for tekniske ändringer
 Tekniske forendringer forbeholdes
 Med reservation för tekniska ändringar
 Tekniset muutokset pidätetään
 Technické zmeny vyhrazeny
 A változtatások technika jogát fenntartjuk
 Zmiany techniczne zastrzeżone
 Επιφυλασσόμεθα για αλλαγές